

HARDWARE INSTALLATION INSTRUCTIONS

# Proximity Wall Switch Reader

## Model: 4100-WS

### General

The Model 4100-WS is a standard indoor/outdoor proximity reader. It is suitable for indoor or outdoor applications.

This reader may be mounted directly to a single gang electrical junction box or any flat surface.



### CommandModule

The 4100-P/WS may be mounted up to 50 feet from the Command Module provided that the 5 volt power conductors are #18 or larger.

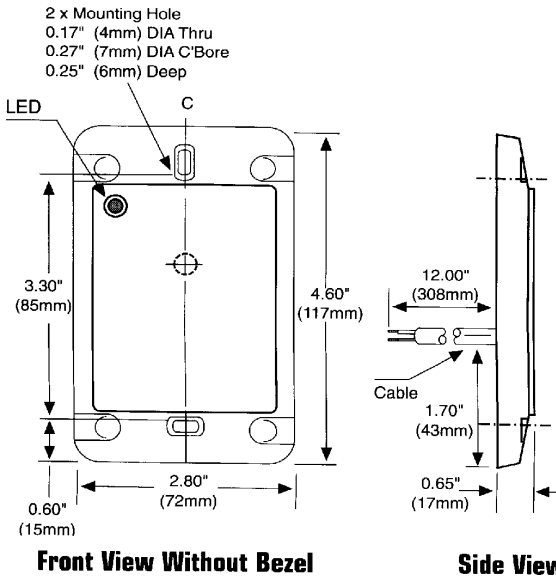

### READER TO MODULE WIRING

